

3-/4-way mixing valves ARV ProClick



Benefits

- For distribution and mixing
- Compact design
- Non-slip rotary knob
- Low torque for increased service life of actuator
- ProClick adapter system for motor mounting without tools

Application

Universal mixing application in water-based heating and cooling systems (radiators, panel heating systems). The 3-way mixer can also be used as a distribution or zone mixer. Suitable for water and water/glycol mixtures with up to 50 % glycol. Not suitable for drinking water.

Versions

	Nominal diameter	Connection	Flow coefficient Kvs	Part no.
3-way mixing valve ARV 382	DN 20	Rp $\frac{3}{4}$	6.3 m ³ /h	15003AP
3-way mixing valve ARV 384	DN 25	Rp1	10 m ³ /h	15011AP
3-way mixing valve ARV 385	DN 32	Rp1 $\frac{1}{4}$	16 m ³ /h	15005AP
3-way mixing valve ARV 386	DN 40	Rp1 $\frac{1}{2}$	25 m ³ /h	15006AP
3-way mixing valve ARV 387	DN 50	Rp2	40 m ³ /h	15007AP
4-way mixing valve ARV 484	DN 25	Rp1	10 m ³ /h	15043AP
4-way mixing valve ARV 485	DN 32	Rp1 $\frac{1}{4}$	16 m ³ /h	15044AP
4-way mixing valve ARV 486	DN 40	Rp1 $\frac{1}{2}$	25 m ³ /h	15045AP
4-way mixing valve ARV 487	DN 50	Rp2	40 m ³ /h	15047AP

Blue part no. = in-stock items



Description

Compact, low-loss 3-way or 4-way mixing valves with brass base and easy-to-handle rotary knob made of high-strength plastic. The rotary knob with scale allows for easy and accurate manual adjustment of the mixing valve. The elevated mark allows for fast position determination. Two scales with "0 to 10" for horizontal installation and "10 to 0" for vertical installation are included for maximum flexibility.

3-way mixing valve for distribution and mixing: The desired flow temperature is obtained via the precise mixing ratio of hot boiler water and cold water from the return line.

4-way mixing valve for dual mixing. The return temperature to the boiler can be high in order to avoid corrosion damage, for example. The mixing valves are easy to automate with the AFRISO actuators. The new AFRISO ProClick adapter system allows for hassle-free mounting of the motor to the mixing valve without tools – snap on and done. The low torque ensures a low load and a long service life.

Technical specifications

Angle of rotation

90°

Operating temperature range

Medium: 5/110 °C

Operating pressure

Max. 10 bar

Flow rate

See ordering table

Leak rate ($\Delta p = 100$ kPa)

DN 20: < 0.2 % Kvs

DN 25: < 0.2 % Kvs

DN 32: < 0.2 % Kvs

DN 40: < 0.5 % Kvs

DN 50: < 0.5 % Kvs

Required torque

DN 20: < 0.5 Nm

DN 25: < 0.5 Nm

DN 32: < 2 Nm

DN 40: < 3 Nm

DN 50: < 3 Nm

Material

Housing: Brass (CW617N)

O rings: EPDM

Technical drawings

ARV 382

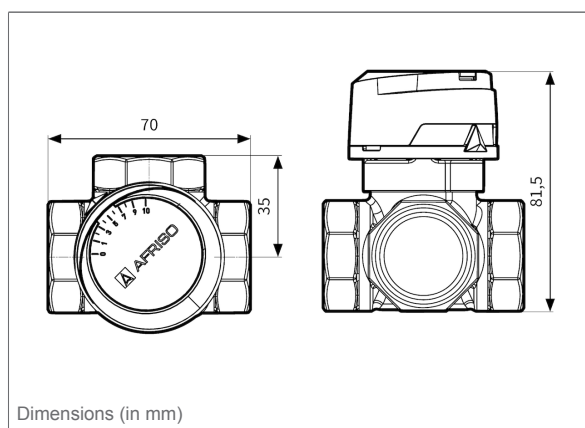

ARV 384

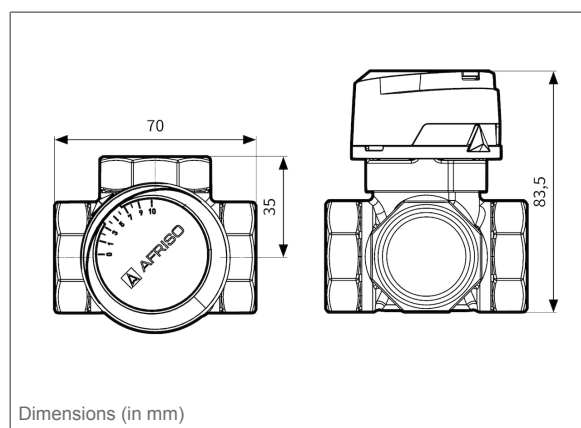

ARV 385

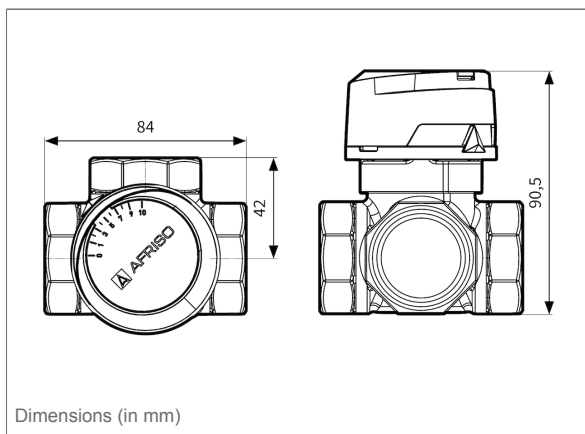

Dimensions (in mm)

ARV 386

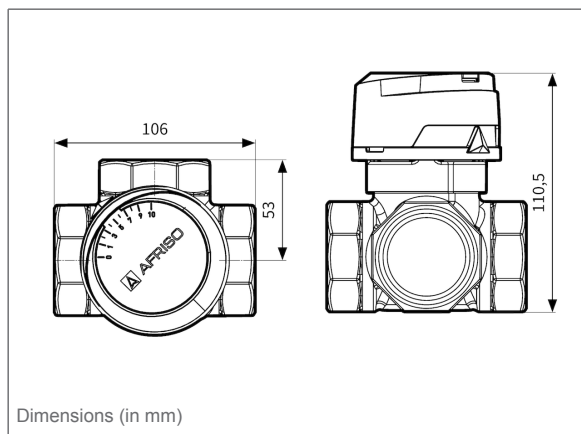

Dimensions (in mm)

ARV 387

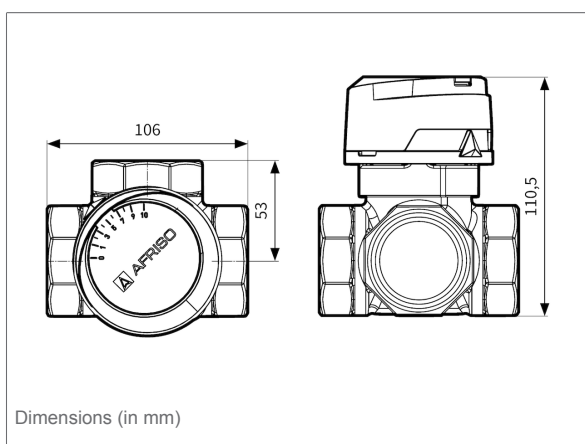

Dimensions (in mm)

ARV 484

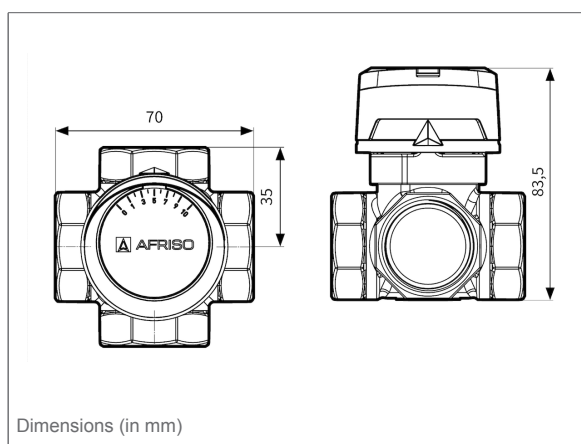

Dimensions (in mm)

ARV 485

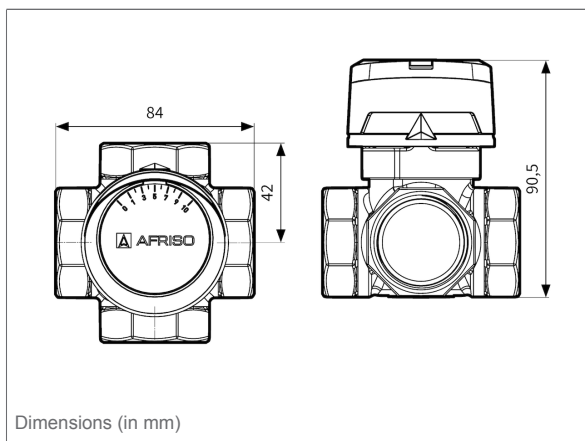

Dimensions (in mm)

ARV 486

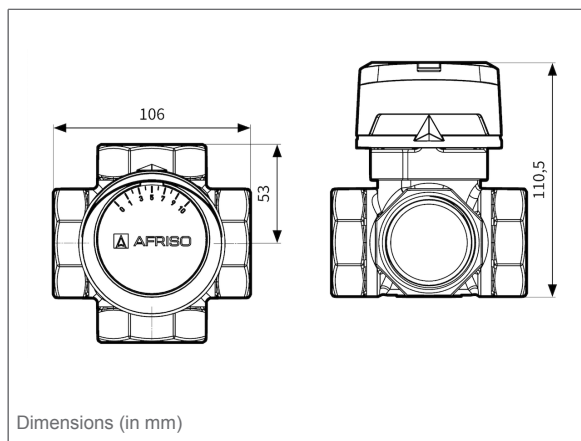

Dimensions (in mm)



ARV 487

